

DIESEL FORKLIFT

**FD10
FD15
FD18**



Engine-choice

Brand	%	ISUZU	XINCHAI	XINCHAI
Model	%	C240PKJ	NB485BPG-7	NC485BPG-508
Rated output	kw/r.p.m.	35.4/2500	30/2600	30/2600
Rated torque	Nm/r.p.m.	139/1800	131/1700-1900	131/1700-1900
No. of cylinder	%	4	4	4
Bore x Stroke	mm	86X102	85X100	85X100
Displacement	cc	2369	2270	2270

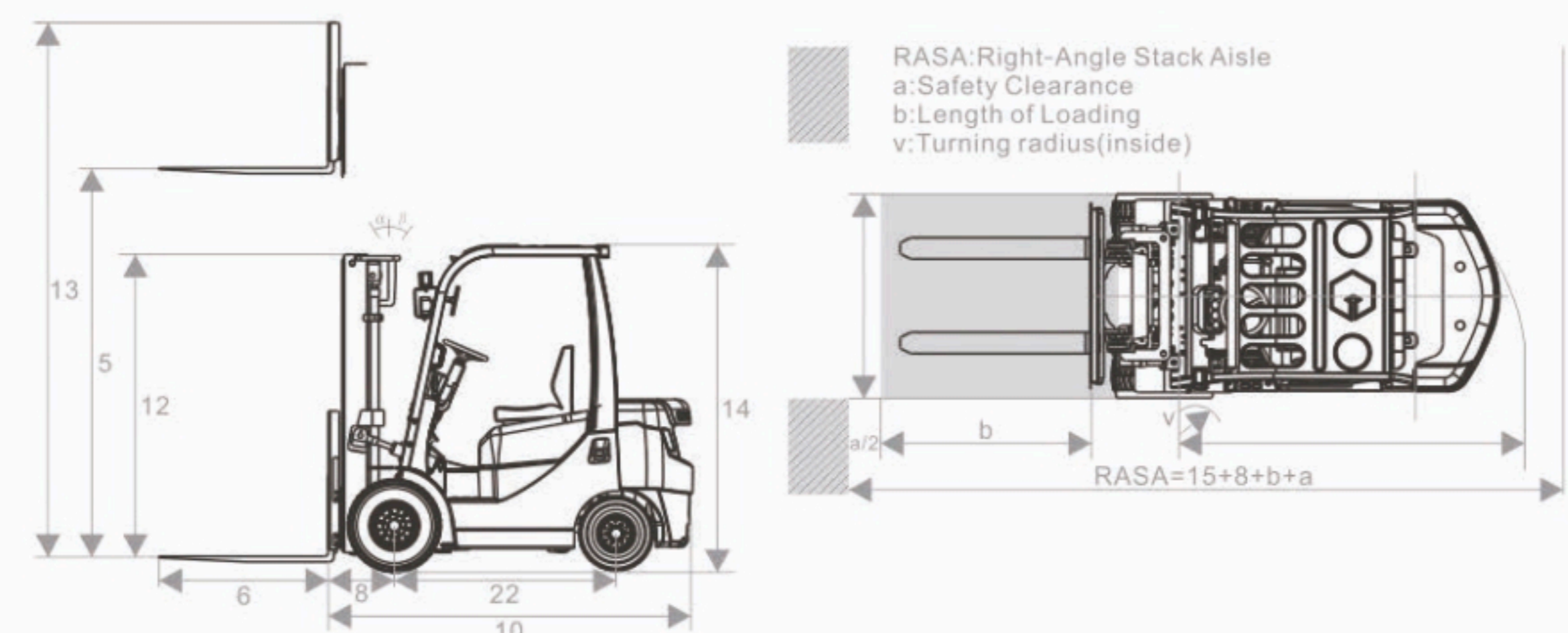
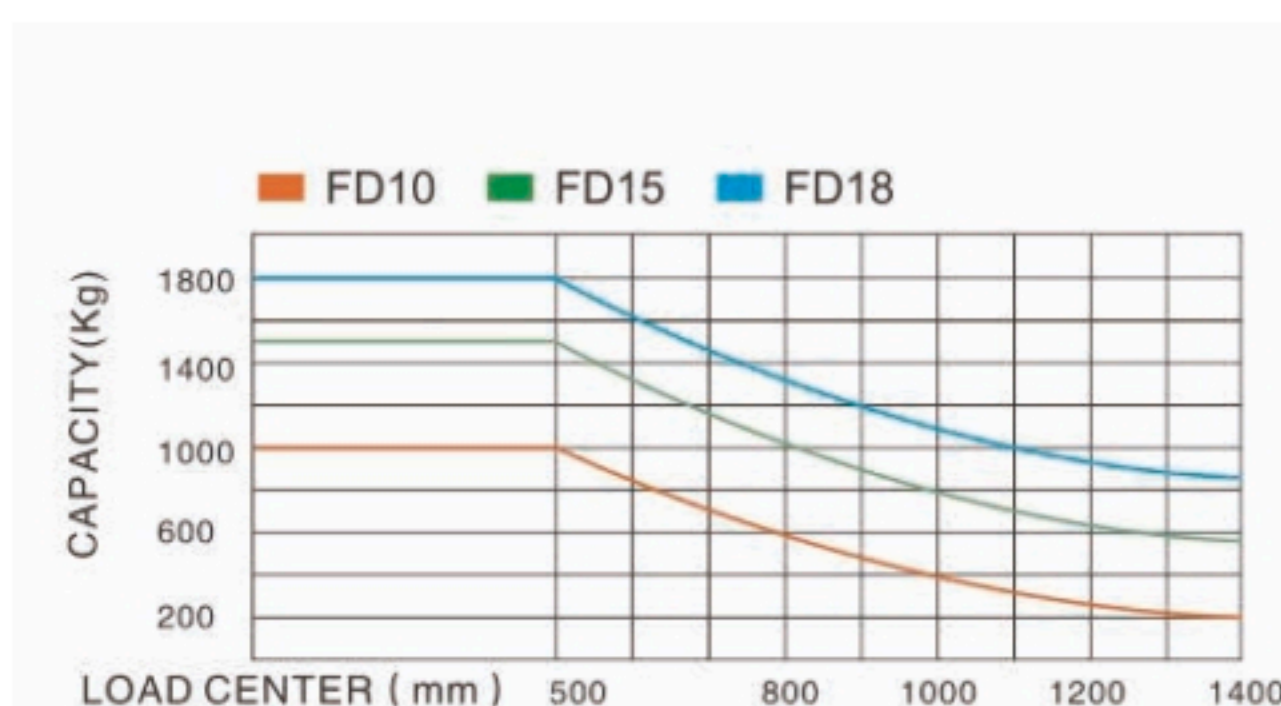

General	1	Model		FD10	FD15	FD18	
	2	Power type		Diesel	Diesel	Diesel	
3	Rated Capacity	kg	1000	1500	1800		
4	Load Centre	mm	500	500	500		
Characteristic & Dimension	5	Lifting Height	mm	3000	3000	3000	
	6	Fork Size	L×W×T	mm	920×120×35	920×120×35	920×120×35
	7	Mast Tilt Angle	F/R	Deg	6°/12°	6°/12°	6°/12°
	8	Front Overhang (Wheel center to fork face)	mm	420	420	420	
	9	Ground Clearance (Bottom of mast)	mm	110	110	110	
	10	Overall Dimension	Length to face of fork (Without fork)	mm	2215	2295	2295
	11		Overall Width	mm	1086	1086	1086
	12		Mast Lowered Height	mm	1995	1995	1995
13	Mast Extended Height (With backrest)		mm	3940	3940	3940	
14	Overhead Guard Height	mm	2040	2040	2040		
Performance	15	Turning Radius (outside)	mm	1975	2055	2055	
	16	Speed	Travel (No load)	km/h	15	15	15
	17		Lifting (Full load)	mm/s	460	450	440
	18	Max.Gradeability (No load/Full load)	%	20	20	20	
Chassis	19	Tire	Front	mm	6.50-10-10PR	6.50-10-10PR	6.50-10-10PR
	20		Rear	mm	5.00-8-8PR	5.00-8-8PR	5.00-8-8PR
	21	Wheelbase	mm	1400	1400	1400	
	22	Service weight	kg	2490	2820	3000	
Power & Transmission	23	Battery	Voltage/Capacity	V/Ah	12/80	12/80	12/80
	24	Engine	Model		C240 PKJ	C240 PKJ	C240 PKJ
	25		Manufacture		ISUZU	ISUZU	ISUZU
	26		Rated output/r.p.m.	kw	35.4/2500	35.4/2500	35.4/2500
	27		Rated torque/r.p.m.	N·m	139/1800	139/1800	139/1800
	28		No.of Cylinder		4	4	4
	29		Bore×Stroke	mm	86×102	86×102	86×102
	30		Displacement	cc	2369	2369	2369
	31		Fuel Tank Capacity	L	45	45	45
	32	Transmission	Type		Hydraulic	Hydraulic	Hydraulic
	33		Stage (FWD/RVS)		1/1	1/1	1/1

Type	Model	Lift Height (mm)	Load Capacity (kg)			Overall Height (mm)			Free Lift (mm)		Tilt Angle F/R(deg)
			1.0t	1.5t	1.8t	Mast Lowered	1.0-1.8t		1.0-1.8t		
							With Backrest	Without Backrest	With Backrest	Without Backrest	
Wide view 2-stage mast	M200	2000	1000	1500	1800	1495	2940	2540	-	-	6/12
	M250	2500	1000	1500	1800	1745	3440	3040	-	-	6/12
	M300	3000	1000	1500	1800	1995	3940	3540	-	-	6/12
	M330	3300	1000	1500	1800	2145	4240	3840	-	-	6/12
	M350	3500	1000	1500	1800	2245	4440	4040	-	-	6/12
	M370	3700	1000	1500	1800	2345	4640	4240	-	-	6/12
	M400	4000	950*1000	1400*1500	1600*1800	2545	4940	4540	-	-	6/12
	M450	4500	800*950	1200*1350	1350*1600	2795	5440	5040	-	-	6/6
	M500	5000	700*850	1100*1300	1150*1500	3045	5940	5540	-	-	6/6
	M550	5500	550*800	800*1200	850*1400	3345	6440	6060	-	-	3/6
Full free 2-stage mast	M600	6000	350*600	550*1000	600*1150	3595	6940	6560	-	-	3/6
	Z200	2000	1000	1500	1800	1495	2940	2540	585	980	6/12
	Z250	2500	1000	1500	1800	1745	3440	3040	835	1230	6/12
	Z300	3000	1000	1500	1800	1995	3940	3540	1085	1480	6/12
	Z330	3300	1000	1500	1800	2145	4240	3840	1235	1630	6/12
	Z350	3500	1000	1500	1800	2245	4440	4040	1335	1730	6/12
	Z370	3700	1000	1500	1800	2345	4640	4240	1435	1830	6/12
	Z400	4000	950*1000	1400*1500	1600*1800	2545	4940	4540	1635	2030	6/12
Full free 3-stage mast	S370	3700	1000	1500	1800	1770	4635	4245	860	1255	6/6
	S400	4000	900*1000	1400*1500	1600*1800	1870	4935	4545	960	1355	6/6
	S435	4350	850*950	1350*1400	1550*1700	1995	5285	4895	1085	1480	6/6
	S450	4500	800*930	1300*1400	1350*1600	2045	5435	5045	1135	1530	6/6
	S480	4800	750*900	1200*1350	1250*1550	2145	5735	5345	1235	1630	6/6
	S500	5000	650*900	1000*1300	1150*1500	2245	5935	5545	1335	1730	6/6
	S550	5500	500*800	700*1200	850*1400	2410	6435	6045	1500	1895	3/6
	S600	6000	300*750	500*1000	550*1150	2595	6935	6545	1685	2080	3/6